

Ref: WAAB0201 POTENTIOMETER FOR 1 PWM PROPORTIONAL SOLENOID VALVE WITH SMALL/HIGH FLOW AND A GRADIENT FLOW ON AN ON/OFF

Data sheet DSENWAAB0201 – september 2016 - Revised : no revised

PRESENTATION

This module regulates the current drawn by the valve's coil according to the position of the potentiometer on the front panel.

The proportional valve aperture is between a minimum and a maximum threshold defined by two potentiometers incorporated on the rear side.

The valve's coil is not supplied when the potentiometer on the front panel is turned in zero position.

A digital input « Forced Stop » authorizes or not the solenoid valve supply.

A digital input « Slow / High flow » allows to divide the valve aperture by 2.

The valve's coil is not supplied when the potentiometer on the front panel is turned in zero position.

The gradient is adjusted by a third potentiometer at the rear side.

A flashing red LED indicates the correct module state.

APPLICATION

- To control an hydraulic proportional valve 12VDC and 24VDC.
- To control an hydraulic motor speed through a proportional valve (2 speeds).

PERFORMANCE

- Power supply : 9VDC to 32VDC.
- Regulation of circulating current in the coil, therefore the valve's aperture is independent of the supply voltage and the oil temperature.
- Accept proportional valves 12VDC and 24VDC (from 0 to 3A).
- Selection of 2 flows or 2 speeds.
- 1 potentiometer on the front panel.
- 3 potentiometers on the rear side (MIN, MAX and GRADIENT).
- By adjusting the MIN and MAX, the whole range of front panel potentiometer is useful.
- Protection against overvoltage, short circuit and reverse polarity.
- Plug-type connector: minifit 8 points.
- Fixing the front panel by the potentiometer barrel.

SUPPLIED ACCESSORIES



1 button to turn the potentiometer (diameter : 28mm, height : 19mm).



1 strand (wires 1mm², 1m, type automotive) with 1 minifit connector



FULFILS THE STANDARDS

- CE mark compliant with 2014/30/UE
- E mark (ECE R10.05) N° 10R-05 13766 compliant with 2009/19/EC
- EMC ISO11452-4
- ESD ISO61000-4-2
- Immunity: ISO7637-2
- Protection: IP66/67
- Vibration-shock: EN60068-2-32;-27;-64;-29
- Supply voltage: 9V à 32V ASAE EP 455-§5.10.1
- Operating temperature: -40, +85°C ASAE EP 455-§5.1.1 et EN60068-2-1;-2;-14;-30;-78
- REACH (1907/2006) and RoHS (2011/65/EU)

Ref: WAAB0201 POTENTIOMETER FOR 1 PWM PROPORTIONAL SOLENOID VALVE WITH SMALL/HIGH FLOW AND A GRADIENT FLOW ON AN ON/OFF

Data sheet DSENWAAB0201 – september 2016 - Revised : no revised

WORKING

If the digital input « Forced Stop » is inactive (closed switch), the solenoid valve is supplied, otherwise the solenoid valve is not supplied.
 If the digital input « small flow (speed) / high flow (speed) » is inactive (closed switch), the flow (speed) is divided by 2.

Small flow = ((high flow - MIN flow) / 2) + MIN flow
 Small speed = ((high speed - MIN speed) / 2) + MIN speed

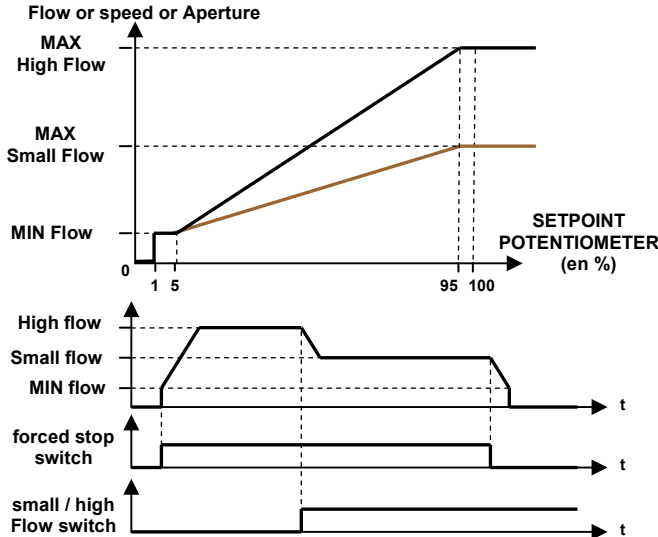

Aperture setting MIN : Set the setpoint potentiometer to 0 (Stop when potentiometer turn in reverse clockwise). Then turn it slightly in the opposite direction until the LED blinks. Set minimal aperture with MIN potentiometer on the rear panel.

Aperture setting MAX : Set the setpoint potentiometer in max stop. (Stop when potentiometer turn in clockwise). Set maximal aperture with MAX potentiometer on the rear panel.

GRADIENT setting : Time between the minimum and maximum aperture opening, setting the GRADIENT potentiometer on the rear panel:

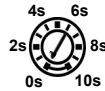

Running red light indicator :

If the valve is opened, the light indicator blinks :

- If 2 flashes: PWM duty cycle < 5%.
- If 4 flashes: PWM duty cycle > 95%.
- If 6 flashes: Valve shorted.
- If 7 flashes: Valve not connected.

Information : If the setpoint potentiometer is lower than 1% of the range or the input « Forced Stop » is active (switch open), the LED is off (1 flash every 5 seconds) and the proportional valve is no longer supplied.

BUILDING IN SAFETY

All brands and all types of electronic modules can fail. Thus the necessary protection against the serious consequences of module failure should always be built into the system. For each application, an assessment should be made for the consequences of electronic module failure and uncontrolled or blocked movements.

NGV ELECTRONIQUE does not always have a complete view of the customer product design and application, so he assumes no liability for applications assistance or customer product design. Customers are responsible for their products and applications using NGV ELECTRONIQUE components. To minimize the risks associated with customer products and applications, customers should provide adequate design and operating safeguards.

NGV ELECTRONIQUE reserve the right to make corrections, modifications, enhancements, improvements, and other changes to its products and services at any time and to discontinue any product or service without notice.

Reproduction of information in this data sheets is permissible only if reproduction is without alteration and is accompanied by all associated warranties, conditions, limitations, and noticed.

FEATURES

	Value		Unit
	MIN	MAX	
Supply voltage	9	32	VDC
Consumption without valve	1	2	mA
Operating temperature	-40	+85	°C
Storage temperature	-40	+90	°C
Valve current supply	0	3	A
Drift current between -25°C and +70°C	0	+/-0.5	%FS
Drift current between 9V and 32V	0	+/-0.5	%FS
Gradient setting	0	10	s
PWM frequency	125		Hz
Weight	30		g

WIRING

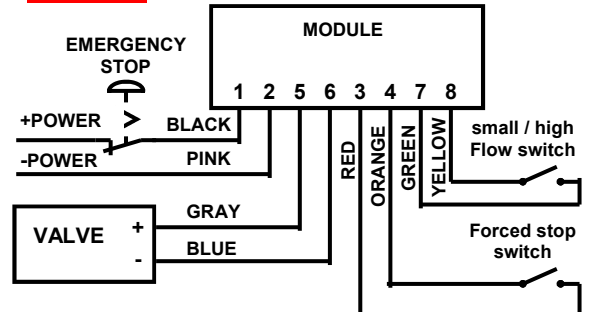

MECHANICAL DESIGN (in mm)

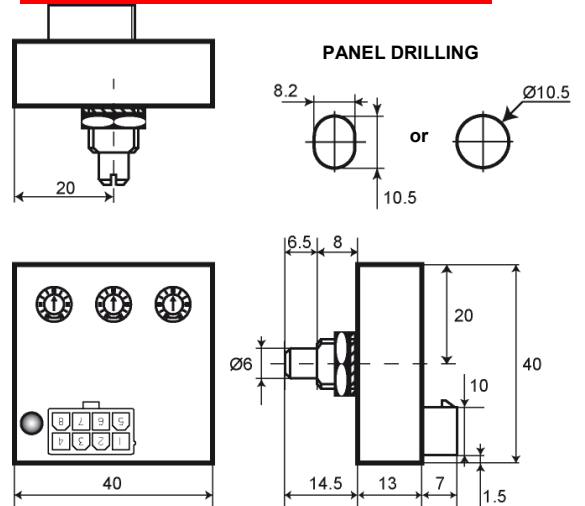

Tracability label description : (example)

V02bf → 02: Software Version, bf: Hardware Version
 Ref: NGDF7536 → Product reference
 Ser: 1611-0003CW → tracability
 16: Year, 11: Month, 0003: serial N°, CW: operator